



DIGITAL INDUSTRIES SOFTWARE

Simcenter FLOEFD Electronics Cooling module

Achieving highly accurate thermal simulation of electronic devices

Benefits

- Accurately predict thermal behavior of electronic devices with compact models
- Validate electronics cooling system performance to achieve long product life
- Efficiently explore methods for cooling electronic devices
- Enable joule heating analysis in complex electronic assemblies

Summary

Siemens Digital Industries Software is a leader in electronics thermal analysis software and thermal characterization test hardware. Simcenter™ FLOEFD™ software is a front-loading computational fluid dynamics (CFD) solution that is designed to work with computer-aided design (CAD) software, so you can simulate airflow and heat transfer using 3D CAD models without the need for data translations or copies. Based on Navier-Stokes equations, it facilitates predicting both laminar and turbulent flows. Simcenter FLOEFD employs one system of equations to describe both laminar and turbulent flows. Moreover, transitioning from a laminar to turbulent state and/or vice versa is handled automatically.

The Simcenter FLOEFD Electronics Cooling module enables you to accurately predict thermal behavior of electronic devices with compact models, validate electronics cooling system performance to achieve long product life, efficiently explore methods for cooling electronic devices and enable joule heating analysis in complex electronic assemblies.

SIEMENS

[siemens.com/simcenter](https://www.siemens.com/simcenter)

The Simcenter FLOEFD Electronics Cooling module provides additional capabilities for the analysis of electronic devices. The physical capabilities in Simcenter FLOEFD Electronics Cooling include:

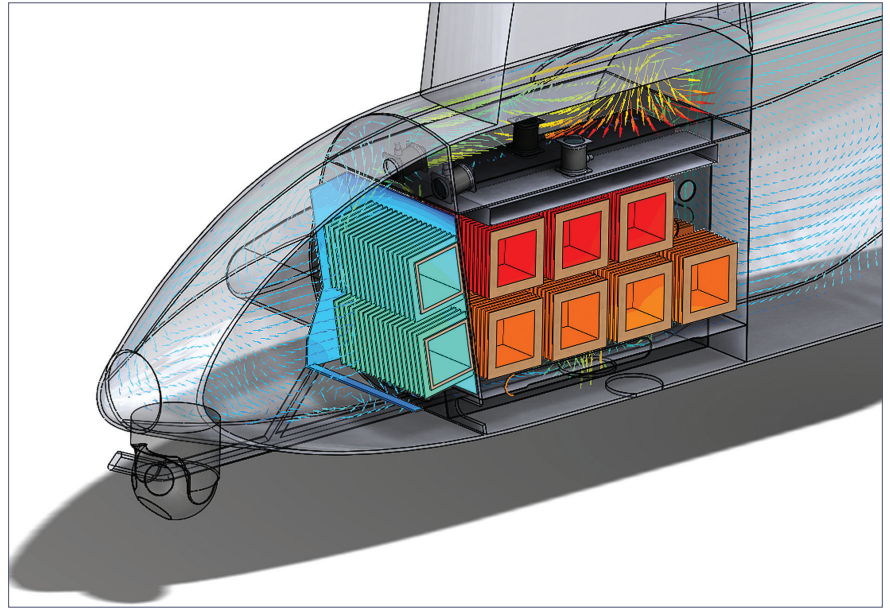

Joule heating

The Simcenter FLOEFD Electronics Cooling module can be used to calculate steady-state direct electric current in electro-conductive solids:

- The Joule heating effect is automatically calculated and included in heat transfer calculations
- The calculations of electric potential and current are performed only in conductive solids; for example, metals and metal-containing composite materials
- The electrical resistivity of the material may be isotropic, anisotropic or temperature dependent

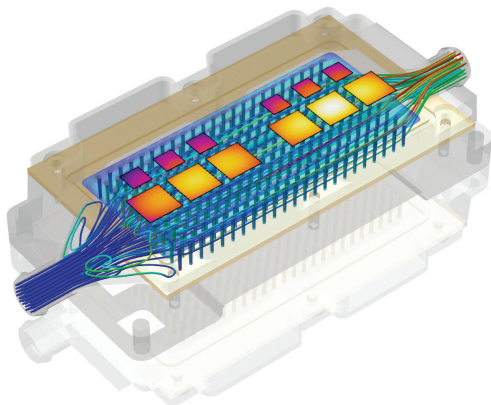

Compact models

To facilitate simulation of electronics equipment, this module offers the following compact models:

- Two-resistor compact model that is test-based on an approved Joint Electron Device Engineering Council (JEDEC) standard
- Built-in library of two-resistor models of standard JEDEC package outlines
- Heat pipe compact model
- Printed circuit board (PCB) model, including PCB generator (more details hereafter)

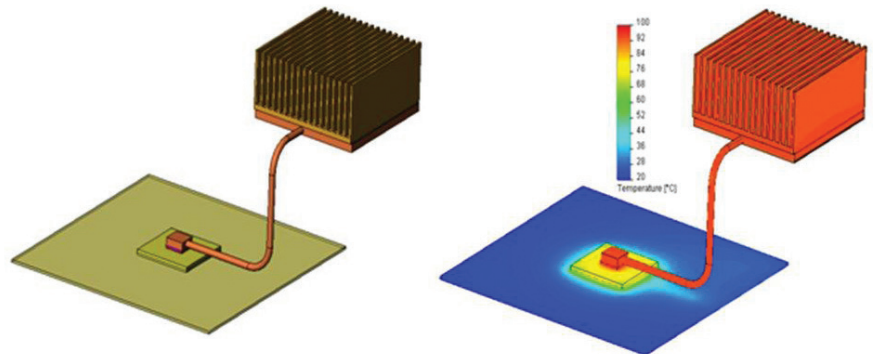

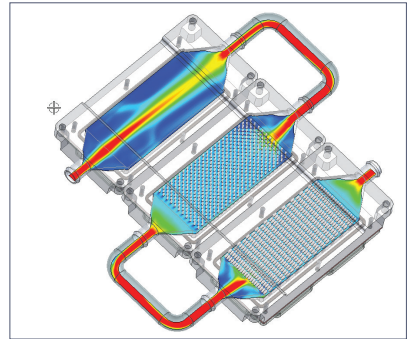
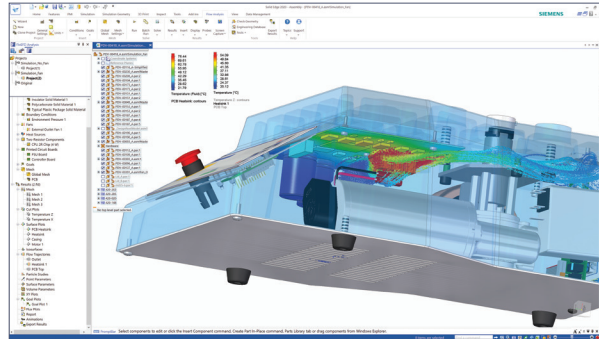
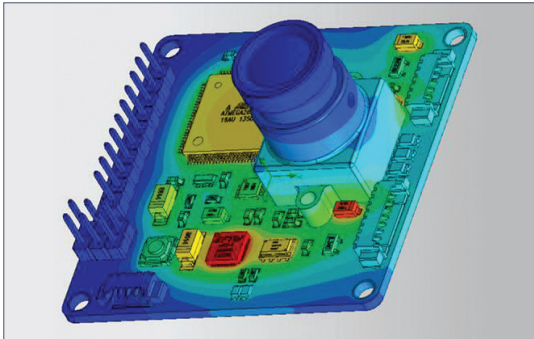

PCB generator

To obtain the bi-axial thermal conductivity values, the following functionality is also available:

- Normal (through plane) and in-plane thermal conductivities automatically derived from the PCB structure and the properties of the specified conductor and dielectric materials
- The board can also be arbitrarily oriented with respect to the global coordinate system; for example, angled PCBs can be modeled

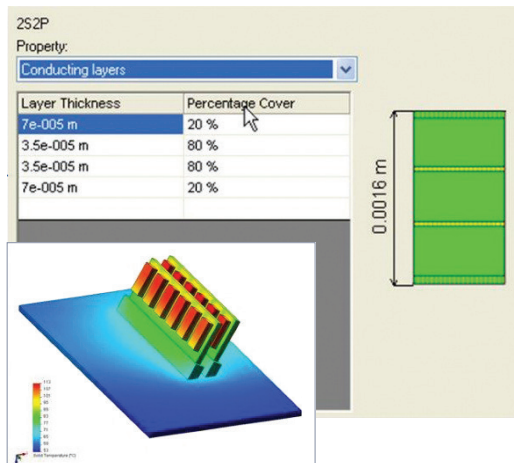

Materials library

In addition to the basic materials, the following are also included in this module:

- More than 1,000 fans from different manufacturers
- Database of solids materials such as alloys, ceramics, metals, polymers, laminates, glasses and minerals and semiconductors
- Database of integrated circuit (IC) packages
- Database of single- and multi-stage thermo-electric coolers (TEC)
- Database of interface materials (contact thermal resistance)
- Database of two-resistor components

Simcenter FLOEFD EDA Bridge is an optional add-on module

For more advanced electronics cooling simulation and interfaces to electronic design automation (EDA) tools, Siemens Digital Industries Software recommends the FLOEFD EDA Bridge module.

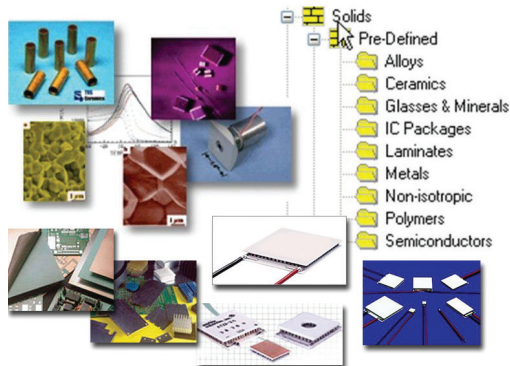

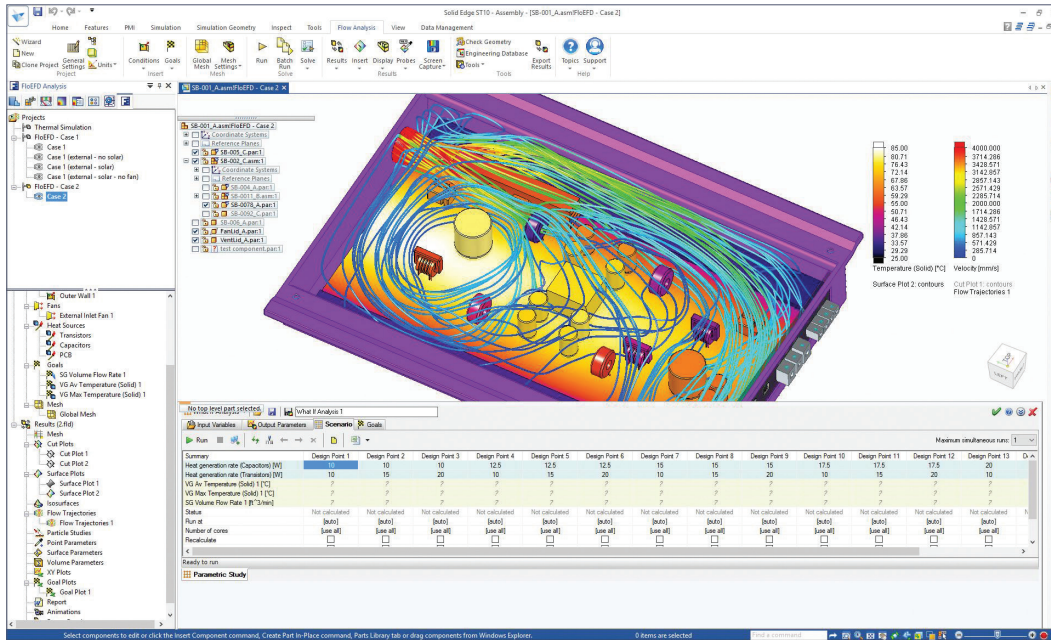

What-if testing made easy

One of the most powerful features of Simcenter FLOEFD is the ease with which you can conduct what-if analyses.

Simcenter FLOEFD makes it simple to modify your models and analyze design variations. First, create your base model and analyze it. Then create multiple variations of your design by modifying the solid model without having to reapply material properties, etc. Using its parametric study and design comparison functionality, you can easily compare the results among the various options to choose your best possible design.

When you are satisfied with your design, publish your report with the touch of a button. You can even publish a fully interactive 3D dynamic plot and share it with colleagues or customers.

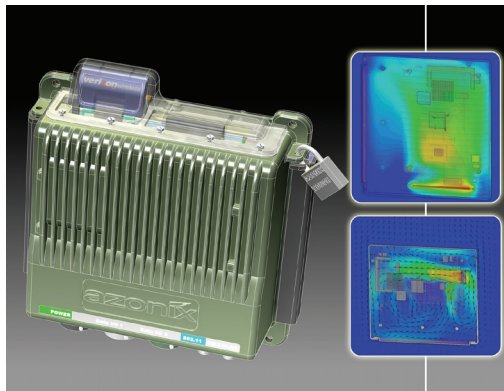

Siemens Digital Industries Software
siemens.com/software

Americas
 1 800 498 5351

Europe
 00 800 70002222

Asia-Pacific
 001 800 03061910

For additional numbers, click [here](#).