



## DIGITAL INDUSTRIES SOFTWARE

# Simcenter E-Machine Design

Delivering a comprehensive virtual laboratory for designing electric machines

### Benefits

- Reduce your reliance on physical prototypes
- Tune accuracy to the appropriate stage of the design
- Combine analytical and finite element method experiments
- Avoid failure from the beginning
- Couple electromagnetic and thermal effects automatically in the same interface

### Summary

Physical tests are time-consuming and expensive, so reducing the need for them is a significant advantage, particularly in rapidly evolving markets such as electric vehicles, drones and energy generation. Using Simcenter™ E-Machine Design software gives electric machine designers and manufacturers a digital laboratory for collecting performance data and allows them to create thousands of virtual prototypes a week.

Simcenter E-Machine Design has a template-driven interface that allows the user to easily describe the rotor and the stator and quickly choose from a range of laboratory experiments.



Electromagnetics

**SIEMENS**

[siemens.com/simcenter](https://www.siemens.com/simcenter)

**Shift machine design and development left**

Using Simcenter E-Machine Design provides machine-specific virtual prototyping for a variety of radial flux and axial flux machines. Developing a machine idea often takes many design iterations. Testing each design with a physical prototype requires material sourcing, supplier quotations, waiting for parts, assembling components and testing. A virtual prototype does not require any sourcing and it is easy to edit when considering alternative designs, significantly reducing the time required for each development cycle.

**Coupled magneto-thermal effects**

Using Simcenter E-Machine Design allows you to couple the magneto-thermal effects from the first step. By doing so, engineers can avoid failures and improve the life of the motor. Consider that for every 10 Celsius (°C) above the designed temperature, the expected product life is reduced by 50 percent.

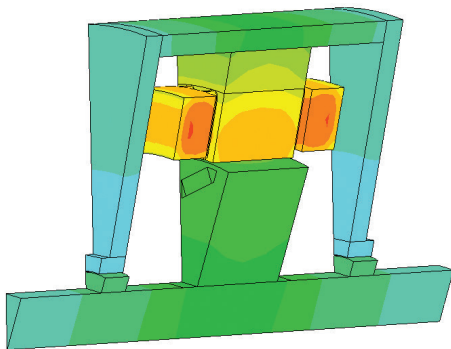

**Tuned accuracy**

Shorten the design process by tuning the accuracy of each experiment to the appropriate stage of the design. For instance, less accurate outcomes can be used during the initial stages of the design to filter out

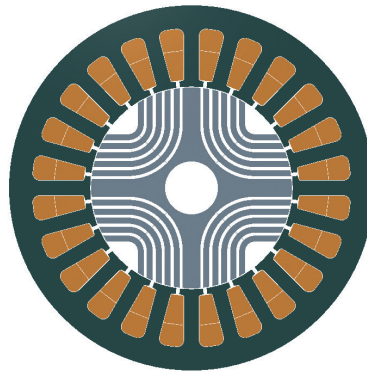

Radial flux machine

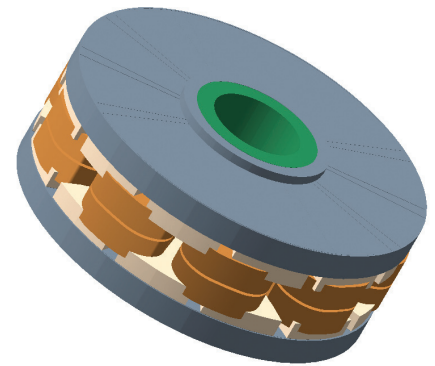

Axial flux machine

pole-slot combinations and the most accurate outcomes can be used when you desire to review saturation or eddy current effects.

**Comprehensive solution**

This is the only product on the market that provides a comprehensive solution for electromagnetic (EMAG) (with analytical EMAG, calibrated analytical EMAG and FEM EMAG) and thermal (calibrated analytical thermal and FEM thermal). Additionally, it is a revolutionary machine design tool that provides parameterized templates and modeling capabilities for both radial and axial flux machines.

**Collaboration and integration into Siemens Xcelerator**

Electric machines never operate standing alone; they are always part of a larger system of components that must work together as an ensemble. To produce a high-end electric machine that is both efficient and silent requires a team of engineers to collaborate. Simcenter E-Machine Design is part of the Siemens Xcelerator business platform of software, hardware and services. As part of the Simcenter family of products, files can be shared with other Simcenter and NX™ software products. NX is also part of Siemens Xcelerator.

This allows you and your colleagues who are responsible for the mechanical, thermal, electronic and assembly of components to work on the most up-to-date files without confusion or bottlenecks via this multi-attribute holistic E-Drive solution.

### Design exploration

Seamlessly combine Simcenter E-Machine Design with HEEDS™ software. With this connection, you can more thoroughly explore design alternatives; consider manufacturing tolerances, minimize magnet volume, maximize torque or use your own figure of merit for developing the machine.

### System simulation

Review your machine's response as part of a system with higher fidelity models. Replace simple machine block representations within the E-Drive system. Use a thorough depiction of your machine's behavior at a variety of operating conditions. Models can be easily generated for Simulink, OPAL-RT, Simcenter AMESIM™ software or generally to FMU or VHDL-AMS standards.

### Proven technology

Simcenter E-Machine Design combines the best of proven and tested software technologies. This includes capabilities from Simcenter SPEED™ software, Simcenter Motorsolve™ software, and Simcenter MAGNET™ software.

Simcenter MAGNET is a low-frequency EMAG solver technology, and it is the framework for all FEM-related capabilities in Simcenter E-Machine Design. Simcenter MAGNET is built on more than four decades of pioneering research and it incorporates a wide range of solvers that include static, time-harmonic, transient and transient with motion options. This technology is designed to solve all machine experiments quickly and efficiently.

### Advantages

- Achieve great accuracy due to outstanding capabilities
- Use fast solvers, adapted and optimized for electric machines
- Benefit from an extensive multi-attribute materials library
- Improve efficiency by including the impact of temperature
- Assess potential risks of demagnetization in permanent magnets
- Run your experiments at multiple operating conditions

Siemens Digital  
Industries Software  
[siemens.com/software](https://www.siemens.com/software)

Americas  
1 800 498 5351

Europe  
00 800 70002222

Asia-Pacific  
001 800 03061910

For additional numbers,  
click [here](#).