

Automobile and transportation

## Voith Turbo

Manufacturer leverages Simcenter Amesim to cut costs and save energy on rail vehicle cooling systems

### Product

Simcenter

### Business challenges

Contain costs and meet delivery deadlines while developing customized cooling systems

Meet customer requirements without building a physical prototype for every new product

Provide customers with information on global train performance

### Keys to success

Extend the use of Simcenter Amesim to locomotive cooling systems design

Model entire cooling system with two water circuits and a series connection for the cooler modules

Build model with required level of system details to get realistic outputs on more complex components

### Results

Reduced number of physical prototypes

### Siemens PLM Software solution enables Voith Turbo to standardize on a global mechatronic simulation platform

The rising cost of energy has had a major impact on railway operators over the past several years. Like other transportation sectors, reducing these costs is becoming a matter of economic survival. For example, the energy cost alone of the three largest European railway networks represents more than €1.75 billion per year. Even though trains are more energy efficient than other transport modes, there is always room for improvement when it comes to reducing environmental impact

and maintaining a competitive advantage in the transportation market.

One of the big concerns for industry leaders is to maintain the appeal of train travel without big price hikes due to energy costs. It will be very important in the coming years to secure the economic viability and competitiveness of the railway systems in regards to other transportation modes. Fortunately for the industry, railway suppliers are already addressing these challenges and deploying advanced technologies in all domains.

Voith Turbo, a division of the Voith AG group, manufactures drive systems that drive and move land and sea machinery, providing safe, reliable and comfortable



### Results (continued)

Optimized design process by using a global mechatronic simulation platform for all product lines

Facilitated analysis of global system behavior

Enhanced competitive advantage by providing customers with more detailed and meaningful data about required systems

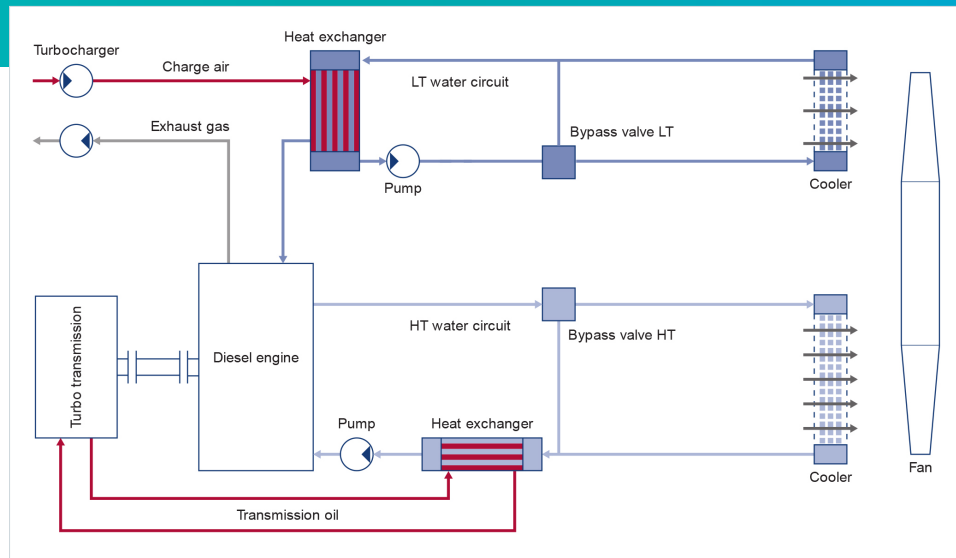

Cooling network with two water circuits for a diesel-hydraulic locomotive.

**“The deployment of this new simulation process helped Voith Turbo access more detailed and meaningful information and data about the required systems.”**

Sebastian Knirsch  
Head of System Engineering  
Voith Turbo Rail

vehicles that facilitate energy savings and emission reductions.

Voith Turbo is divided into four divisions: industry, rail, road and marine. Voith Turbo Rail is one of the leading suppliers of systems and components for rail vehicles. Voith Turbo components and systems are found in low-floor trams and high-speed and tilting trains.

Part of Voith Turbo Rail, Voith Turbo Cooling Systems’ technology operates in mainline and shunting locomotives, railcars and high-speed trains all around the globe.

Voith Turbo Cooling Systems plans and supplies complete cooling systems for diesel-hydraulic, diesel-electric and electric locomotives and railcars of all power classes with variable speed fan drives for a variety of train manufacturers and operators.

With a global cooling system design process, the team at Voith Turbo faced critical engineering and economic issues. To start with, the rail industry is based more on customized systems with a strong focus on product quality, reliability and

robustness for customers like Bombardier, Siemens and Alstom. One of the most specific and difficult issues – compared to the automotive industry – is the variety of cooling systems.

Considering the various environmental conditions in which trains operate – from the monsoons of India to the snows of Finland – one can understand how this could affect the efficiency of a cooling system. With the considerable challenges in juggling all the different requirements of the diverse cooling systems, it was essentially a design-on-demand situation, which could lead to uncontrollable costs and delays.

Another major issue was the absence of a standard driving cycle: each customer has its own specific parameters, such as train station positions and starting and ending points, not to mention specific requirements for fuel consumption, noise and power values. Building a physical prototype for every new cooling system request would be too expensive since re-use was not possible due to the different customer platforms.

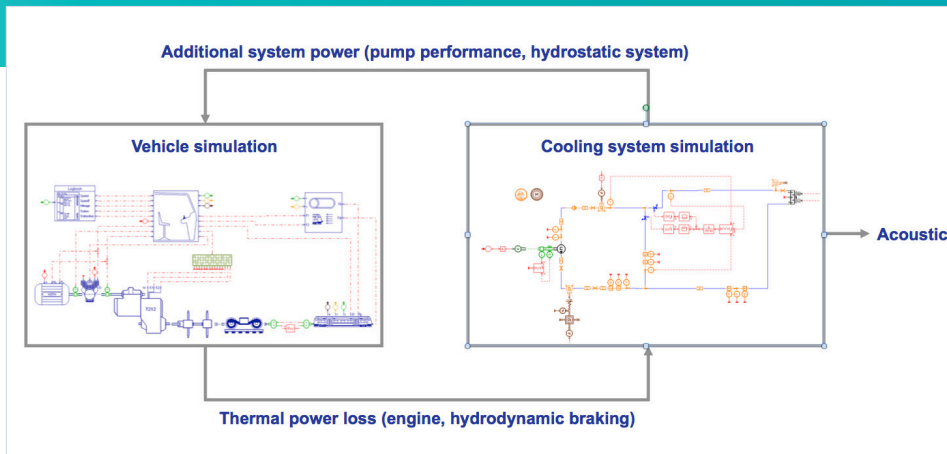

Interaction of the cooling unit and the vehicle-track simulation.

## “Introducing Simcenter Amesim was an important change in the design process.”

Sebastian Knirsch  
Head of System Engineering  
Voith Turbo Rail

Finally, each customer wants to know precisely how the entire train would perform: how fast will the train be with each cooling system? What are the acceleration capabilities? What about energy consumption as well as sound level? All these system parameters have to be taken into account and that adds a huge strain to the development process.

Voith Turbo has been using Simcenter Amesim™ software from product lifecycle management (PLM) specialist Siemens PLM Software to design its DIWA transmission as well as for heat recovery systems and railcar powertrain for years. So the jump to cooling systems design for locomotives and thermal studies was rather straightforward. Simcenter Amesim was integrated into the design process for the locomotive cooling systems.

The Voith Turbo Cooling Systems’ engineers modeled the entire cooling system with two water circuits, the first for a low temperature and the second for a high temperature as well as a series connection for the cooler modules. The model provided the required level of system details to get realistic outputs of more complex components, such as hydrostatic transmission circuits and aerodynamic fan characteristics.

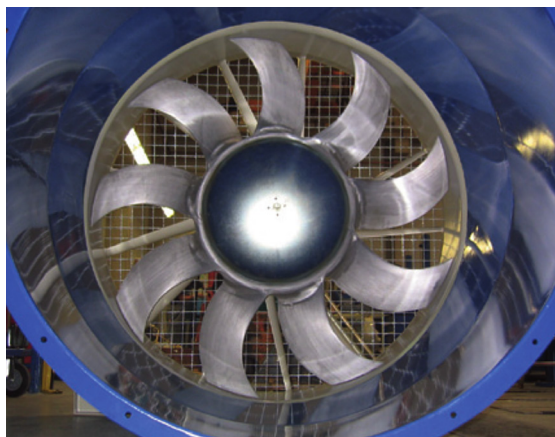

Voith Turbo’s SilentVent combines optimized aerodynamic characteristics with significant noise reduction.

## Solutions/Services

Simcenter Amesim  
[www.siemens.com/plm/simcenter-amesim](http://www.siemens.com/plm/simcenter-amesim)

## Customer's primary business

Voith Turbo, a division of the Voith AG group, manufactures drive systems that efficiently drive and move land and sea machinery, developing safe, reliable and comfortable vehicles that facilitate saving energy and reducing emissions.  
[www.voith.com](http://www.voith.com)

## Customer location

Heidenheim  
Germany

With this comprehensive model, the team could easily analyze global system behavior (including thermal performance) and total input power as well as access controls quality data. Simcenter Amesim proved to be the perfect tool for design and controls optimization.

"Introducing Simcenter Amesim was an important change in the design process," says Sebastian Knirsch, head of systems engineering at Voith Turbo Rail. "We have a better understanding of the system than before, when our knowledge was based only on the physical experiments that we conducted on previous products. The deployment of this new simulation process helped Voith Turbo access more detailed and meaningful information and data about the required systems.

"Some examples might include the heat power released; the temperature levels achieved between two train stations; global energy consumption; and the noise levels on each part of the rail. And being about to share this information with our customers gives us a very strong competitive advantage.

"Simcenter Amesim has become the global mechatronic simulation platform at Voith Turbo. We use the software for all our simulations on all product lines in this division every day."

*"Simcenter Amesim has become the global mechatronic simulation platform at Voith Turbo. We use the software for all our simulations on all product lines in this division every day."*

Sebastian Knirsch  
Head of System Engineering  
Voith Turbo Rail

## Siemens PLM Software

Americas +1 314 264 8499  
Europe +44 (0) 1276 413200  
Asia-Pacific +852 2230 3308

© 2018 Siemens Product Lifecycle Management Software Inc. Siemens and the Siemens logo are registered trademarks of Siemens AG. Femap, HEEDS, Simcenter 3D and Teamcenter are trademarks or registered trademarks of Siemens Product Lifecycle Management Software Inc. or its subsidiaries in the United States and in other countries. Simcenter, Simcenter Amesim, LMS Samtech Samcef, LMS Samcef Caesam, Simcenter SCADAS, Simcenter Testxpress, Simcenter Soundbrush, Simcenter Sound Camera, Simcenter Testlab and LMS Virtual.Lab are trademarks or registered trademarks of Siemens Industry Software NV or any of its affiliates. Simcenter STAR-CCM+ and STAR-CD are trademarks or registered trademarks of Siemens Industry Software Computational Dynamics Ltd. All other trademarks, registered trademarks or service marks belong to their respective holders.

[www.siemens.com/plm](http://www.siemens.com/plm)

35365-A17 7/18 A